

Spare parts list
(5.971-969.0) Spare parts list high-pressure 9/20-4M *

DE HINWEISE

Weitere Sprachen:

Diese Ersatzteilliste ist in weiteren Sprachen erhältlich. Sie erhalten diese unter www.kaercher.com im Bereich Service. Die Schreibweise der Teilenummer, z.B. 75456380, entspricht der Teilenummer 7.545-638.0.

Mengenangaben:

Die Mengenangaben in der Ersatzteilliste entsprechen den in der Baugruppe verbauten Stückzahlen der Bauteile.

Meterware:

Ersatzteile welche als Meterware geliefert werden sind auf Einbaulänge selbst zu kürzen. Die Stückzahlen sind als Mindestbestellmenge =1m angegeben und müssen je nach Bedarf auf weitere volle Meterzahlen erhöht werden.

Versionen/ Werknummern:

Sind Versionen oder Werknummern in der Ersatzteilliste angegeben, ist anhand dieser vor Bestellung zu prüfen, welches Bauteil für ihr Gerät verwendet werden muss.

Lackierte Teile:

Bei Bestellungen von lackierten Teilen welche in der Ersatzteilliste nicht in verschiedenen Farben ausgewiesen sind, ist zusätzlich die Farbnummer oder Farbe mit anzugeben.

Technische Änderungen:

Technische Änderungen sowie das Recht der ausschließlichen Auswertung unseres geistigen Eigentums behalten wir uns vor.

EN INSTRUCTIONS

Other languages:

This list of spare parts is also available in other languages. You can get this list from www.kaercher.com in the Service division. The designation of the part number e.g. 75456380 is equal to 7.545-638.0.

Quantity details:

The quantity details in the spare parts list correspond to the number of pieces of the component installed in the assembly group.

Piece goods:

Spare parts that are sold as piece goods are to be cut to the desired length. The quantities have been indicated as minimum order quantity =1m and must be rounded off to the full meter figure depending on your requirements.

Version/ Plant numbers:

If version or plant numbers are mentioned in the spare parts list, then use the same to check before ordering which spare part needs to be used for your appliance.

Painted parts:

While ordering painted parts that are not mentioned in the spare parts list in their colour variations, please mention the colour number or the colour you require.

Technical changes:

We reserve the right to make technical changes as well as the right to exclusive use of our intellectual property.

FR REMARQUES

Autres langues:

Cette liste de pièces de rechange est disponible en autres langues. Cela est disponible sous www.kaercher.com dans le menu Service. La désignation du numéro de pièce, par ex. 75456380, correspond au numéro de pièce 7.545-638.0.

Indications de quantité:

Les indications de quantité dans la liste de pièces de rechange correspondre aux nombres de pièces des composant utilisées dans la construction.

Matériel au mètre:

Les pièces de rechange qui sont livrées au mètre doivent être raccourcies à longueur souhaitée par l'acheteur même. Les nombres des pièces sont indiquées en quantité de commande minimale = 1m et doivent être augmentés selon le besoin à une chiffre de mètre complète.

Versions/ Numéros d'usine:

Lorsqu'il sont indiquées des versions ou des numéros d'usine dans la liste de pièces de rechange, vous devez vérifier que composant doit être utilisé pour votre appareil.

Pièces laquées:

Pour commander des pièces laquées, où les différentes couleurs ne sont pas indiquées dans la liste des pièces de rechange, vous devez indiquer en plus le numéro de la couleur ou seulement la couleur.

Modifications techniques:

Nous nous réservons la possibilité des modifications techniques ainsi le droit d'exploitation exclusive de notre propriété intellectuelle.

IT AVVERTENZE

Altre lingue:

Il presente elenco di parti di ricambio è disponibile sul nostro sito Web anche in altre lingue: sotto www.kaercher.com alla voce "Service".

L'indicazione del codice pezzo, ad es. 75456380, corrisponde al codice pezzo 7.545-638.0

Indicazioni di quantità:

Le indicazioni di quantità riportate dall'elenco "parti di ricambio" corrispondono al numero delle singole componenti contenute nella rispettiva unità.

Merce a metro:

Le parti di ricambio fornite come "merce a metro" devono venire in seguito accorciate alla lunghezza necessaria per il montaggio. La quantità unitaria è indicata come "quantità minima di ordinazione = 1m" e deve all'occorrenza venire moltiplicata per il numero intero di metri necessari.

Versioni / Numeri di fabbricazione:

Quando l'elenco "parti di ricambio" riporta diverse versioni o numeri di fabbricazione, confrontare la versione o il numero di fabbricazione del ricambio desiderato con quelle/i presenti nell'elenco e indicarla/o al momento dell'ordinazione.

Parti di ricambio verniciate:

Nel caso di ricambi verniciati, se l'elenco parti di ricambio non ne riporta espressamente i diversi colori, al momento dell'ordinazione è necessario indicare anche il colore o il numero del colore desiderato.

Modifiche tecniche:

Ci riserviamo il diritto di apportare modifiche tecniche così come il diritto di utilizzo esclusivo della nostra proprietà intellettuale.

ES INDICACIONES

Otros idiomas:

La lista de piezas de repuesto se puede adquirir en otros idiomas. La puede adquirir en www.kaercher.com en el área de servicios.

La notación de los números de las piezas, p.ej. 75456380 corresponde al número de pieza 7.545-638.0.

Cantidades:

Las indicaciones de cantidades de la lista de piezas de repuesto corresponden al número de piezas montadas en el componente.

Mercancía por metros:

Las piezas de repuesto que se suministran por metros se pueden cortar al largo deseado. La unidad mínima de pedido es de = 1 m y el número de metros completos se puede aumentar según necesidad.

Versiones/números de fábrica:

Si se indica la versión o número de fábrica en la lista de piezas de repuesto, se debe comprobar en ella la pieza a usar para su aparato antes de realizar el pedido.

Piezas lacadas:

Al realizar pedidos de piezas lacadas que no estén indicadas en los diferentes colores en la lista de piezas de repuesto, se debe indicar también la referencia del color o el color.

Modificaciones técnicas:

Reservados los derechos de realizar modificaciones técnicas y aprovechar nuestra propiedad intelectual.

PL WSKAZÓWKI

Pozostałe języki:

Ta lista części zamiennych jest dostępna w także w innych językach. Mogą ją Państwo pobrać ze strony www.kaercher.com w dziale Serwis.

Sposób zapisywania numeru części, np. 75456380, odpowiada numerowi części 7.545-638.0.

Dane ilości:

Dane ilości podane w liście części zamiennych odpowiadają liczbie sztuk podzespołów tworzących dany moduł.

Towar sprzedawany na metry:

Części zamienne dostarczane jako towar sprzedawany na metry po zamontowaniu należy samodzielnie skrócić do potrzebnej długości. Liczba sztuk podana jest jako minimalna ilość zamówienia = 1m i w zależności od potrzeb zwiększa się ją o kolejne pełne metry.

Wersje/ Numer zakładu:

Jeżeli w liście części zamiennych podane są wersje lub numery zakładu, przed zamówieniem na ich podstawie należy sprawdzić, który podzespół stosuje się w Państwa urządzeniu.

Części lakierowane:

W przypadku zamówień części lakierowanych, które w liście części zamiennych nie podano w wielu kolorach, należy dodatkowo zaznaczyć nr koloru lub kolor.

Zmiany techniczne:

Zastrzegamy sobie prawo do zmian technicznych oraz wyłącznego wykorzystywania naszej własności intelektualnej.

RU УКАЗАНИЯ:

Другие языки:

Данный список запасных частей также доступен на других языках. Вы найдете его на сайте www.kaercher.com в разделе Service
Маркировка номера детали, например, 75456380, соответствует номеру детали 7.545-638.0.

Указание количества:

Количественные данные в списке запасных частей соответствуют числу компонентов, входящих в состав узлов.

Товар, продаваемый на метры:

Запасные части, продающиеся на метры, необходимо обрезать до нужной длины. Число изделий указано в виде минимального объема заказа = 1м и их количество можно округлить до требуемого по мере необходимости.

Варианты исполнения/заводские номера:

Если варианты исполнения или заводские номера указаны в списке запасных частей, то перед заказом необходимо проверить, какая деталь подходит для вашего устройства.

Лакированные детали:

При заказе лакированных деталей, варианты расцветки которых не указаны в списке запасных частей, необходимо дополнительно указать номер цвета или необходимый для вас цвет.

Технические изменения:

Мы оставляем за собой право на технические изменения, а также право на исключительное использование нашей интеллектуальной собственности.

Table of contents

Spare parts list high-pressure 9/20-4M * (5.971-969.0)	6
10 Housing.....	7
3 Cover HD Basis/Mittelklasse Anthrazit (4.069-025.0).....	9
8 Proportioning valve chemistry (4.580-645.0).....	10
10 Cover cleaning agents complete (4.060-866.0).....	11
20 Pump set.....	12
21 Cylinder head.....	13
11 Pressure gauge complete (4.423-024.0).....	16
20 Valve complete (4.580-594.0).....	17
22 Thrust guidance.....	19
4 Piston complete (4.553-279.0).....	21
30 Motor.....	23
40 Accessories.....	26
41 Hand trigger gun.....	27
1 HAND TRIGGER GUN EASY PRESS (4.775-463.0).....	29
999 Manifold complete only for replacement (4.427-215.0).....	30
999 Lever complete (4.481-209.0).....	32
4 Lever complete (4.481-209.0).....	34
6 Manifold complete only for replacement (4.427-215.0).....	36
42 Rotary controller.....	38
1 Rotary controller 416L (4.775-470.0).....	40
43 High pressure hose.....	42
44 Jet pipe.....	44
1 Jet pipe packaged only for replacement (4.760-660.0).....	46
45 Triple jet nozzle.....	48
0 Triple jet nozzle only for replacement 0 (4.767-154.0).....	50
2 Spare parts list triple jet nozzle.....	51
10 Triple jet nozzle plastics.....	52
20 Triple jet nozzle brass.....	54
50 Electric box.....	56

Spare parts list high-pressure 9/20-4M * (5.971-969.0)

Pos	Name	Qty.	Unit
10	Housing	1.000	ST
20	Pump set	1.000	ST
30	Motor	1.000	ST
40	Accessories	1.000	ST
50	Electric box	1.000	ST

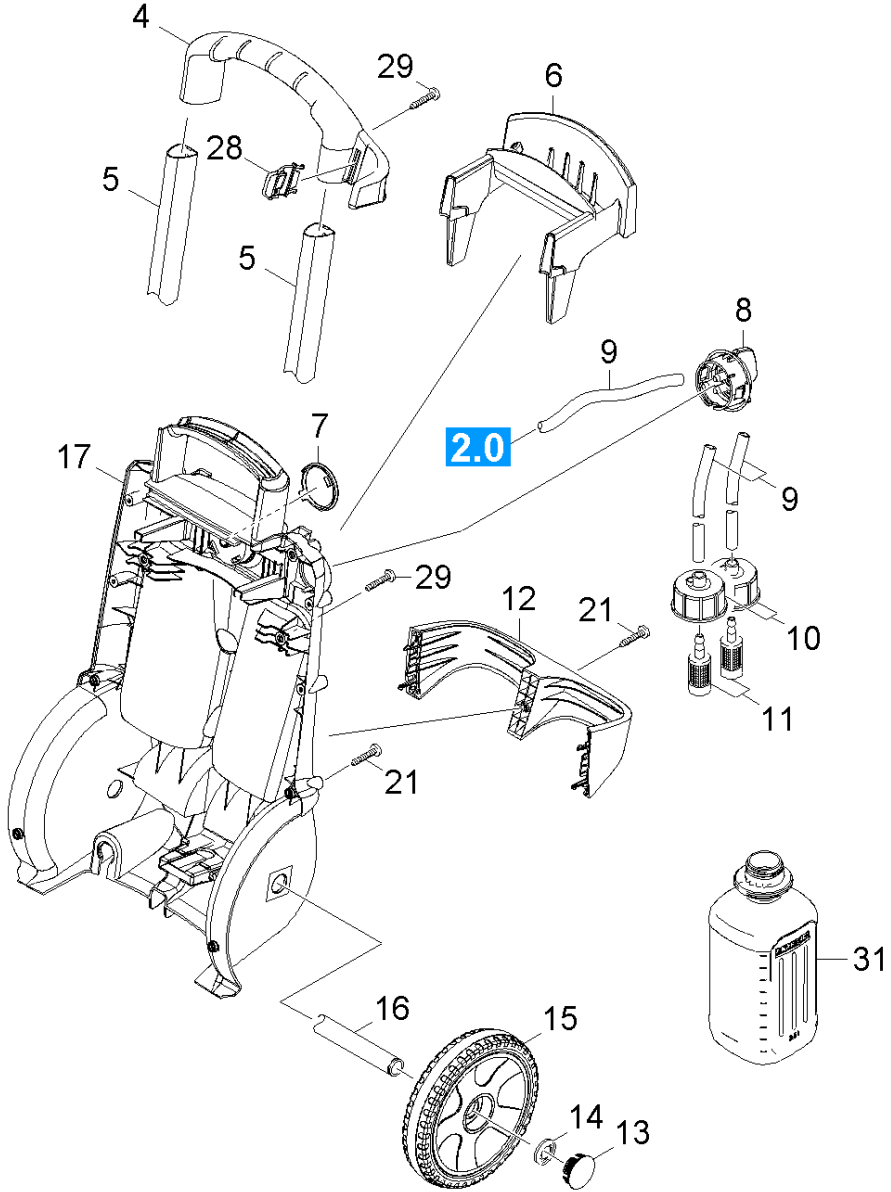
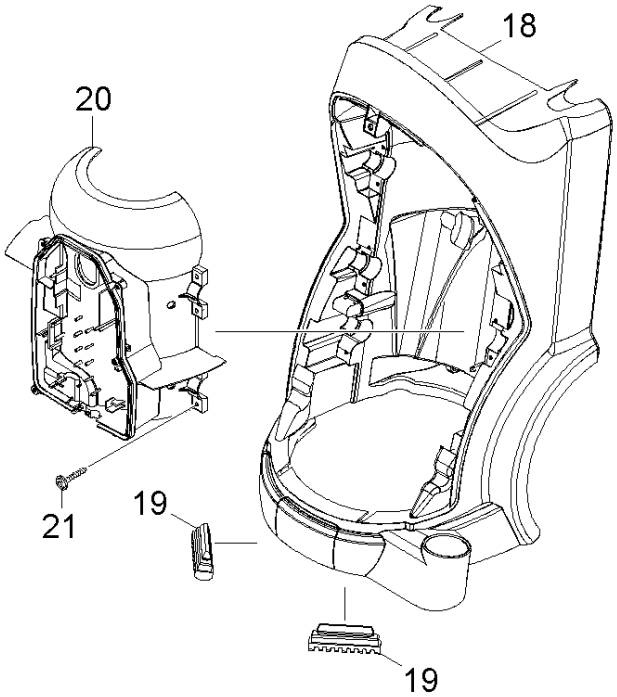
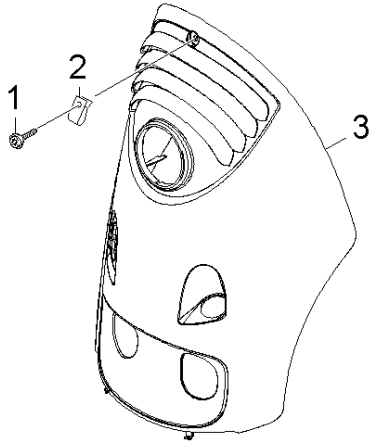

10 Housing

ET/VT (spare/wear parts)	Pos	Material #	Name	Qty.	Unit	from ser.nr.	up to ser.nr.	Footnote text
	1	6.304-099.0	Saucer-head screw M 6x 18-4.8-R2R	1.000	ST	0000000000	0000000000	
	2	6.310-053.0	Putting nut	1.000	ST	0000000000	0000000000	
X-X	3	4.069-025.0	Cover HD Basis/Mittelklasse Anthrazit	1.000	ST	0000000000	0000000000	
	4	5.321-751.0	Handhold	1.000	ST	0000000000	0000000000	
	5	5.107-262.0	Bar	2.000	ST	0000000000	0000000000	
	6	5.044-735.0	Holder	1.000	ST	0000000000	0000000000	
	7	5.032-475.0	Covering cap cover	1.000	ST	0000000000	0000000000	
	8	4.580-645.0	Proportioning valve chemistry	1.000	ST	0000000000	0000000000	
	9	6.388-216.0	Hose DN 5	1.000	M	0000000000	0000000000	TO ORDER AS CUT GOODS
X	10	4.060-866.0	Cover cleaning agents complete	2.000	ST	0000000000	0000000000	
	11	5.731-652.0	Filter with weight	2.000	ST	0000000000	0000000000	
	12	5.032-747.0	Retaining bracket	1.000	ST	0000000000	0000000000	
X-X	13	2.889-086.0	Set wheel cap	1.000	ST	0000000000	0000000000	SET OF 2 PIECES
	14	6.343-217.0	Clamping washer D25	2.000	ST	0000000000	0000000000	
X-X	15	4.515-320.0	Wheel complete	1.000	ST	0000000000	0000000000	SET OF 2 PIECES
	16	5.105-413.0	Axle	1.000	ST	0000000000	0000000000	
	17	5.050-431.0	Frame rear panel	1.000	ST	0000000000	0000000000	
	18	5.050-258.0	Frame front part	1.000	ST	0000000000	0000000000	
	19	5.057-062.0	Support	2.000	ST	0000000000	0000000000	
	20	5.692-083.0	Air circulation electric control box bot	1.000	ST	0000000000	0000000000	
	21	7.303-108.0	Screw 5x20 -10.9-R2R (In6Rd)	19.000	ST	0000000000	0000000000	
	28	5.044-216.0	Holder	1.000	ST	0000000000	0000000000	
	29	7.303-048.0	Screw M6x20 -St-R3R (In6Rd)	8.000	ST	0000000000	0000000000	
	31	6.394-491.0	Bottle PE 2,5 L	2.000	ZST			

3 Cover HD Basis/Mittelklasse Anthrazit (4.069-025.0)

ET/VT (spare/wear parts)	Pos	Material #	Name	Qty.	Unit
X	2	6.277-083.0	Bag neutrally 500 X 800 X 0,1 mm-PE	1.000	ST
	3	6.376-036.0	Label spare parts neutrally 65x55 MM	1.000	ZST

8 Proportioning valve chemistry (4.580-645.0)

Pos	Material #	Name	Qty.	Unit
5		Grease	0.400	G
6	6.362-085.0	O-Ring seal 32,0 X 2,5-NBR 70	1.000	ST
7	6.362-498.0	O-Ring seal 6,75x1,78 NBR 70	1.000	ST
8	6.362-856.0	O-Ring seal 4,47X 1,78	2.000	ST
10	6.376-020.0	Label 65X55 MM	1.000	ZST

10 Cover cleaning agents complete (4.060-866.0)

Pos	Material #	Name	Qty.	Unit
2	6.363-304.0	Seal	1.000	ST

20 Pump set

Pos	Name	Qty.	Unit
21	Cylinder head	1.000	ST
22	Thrust guidance	1.000	ST

21 Cylinder head

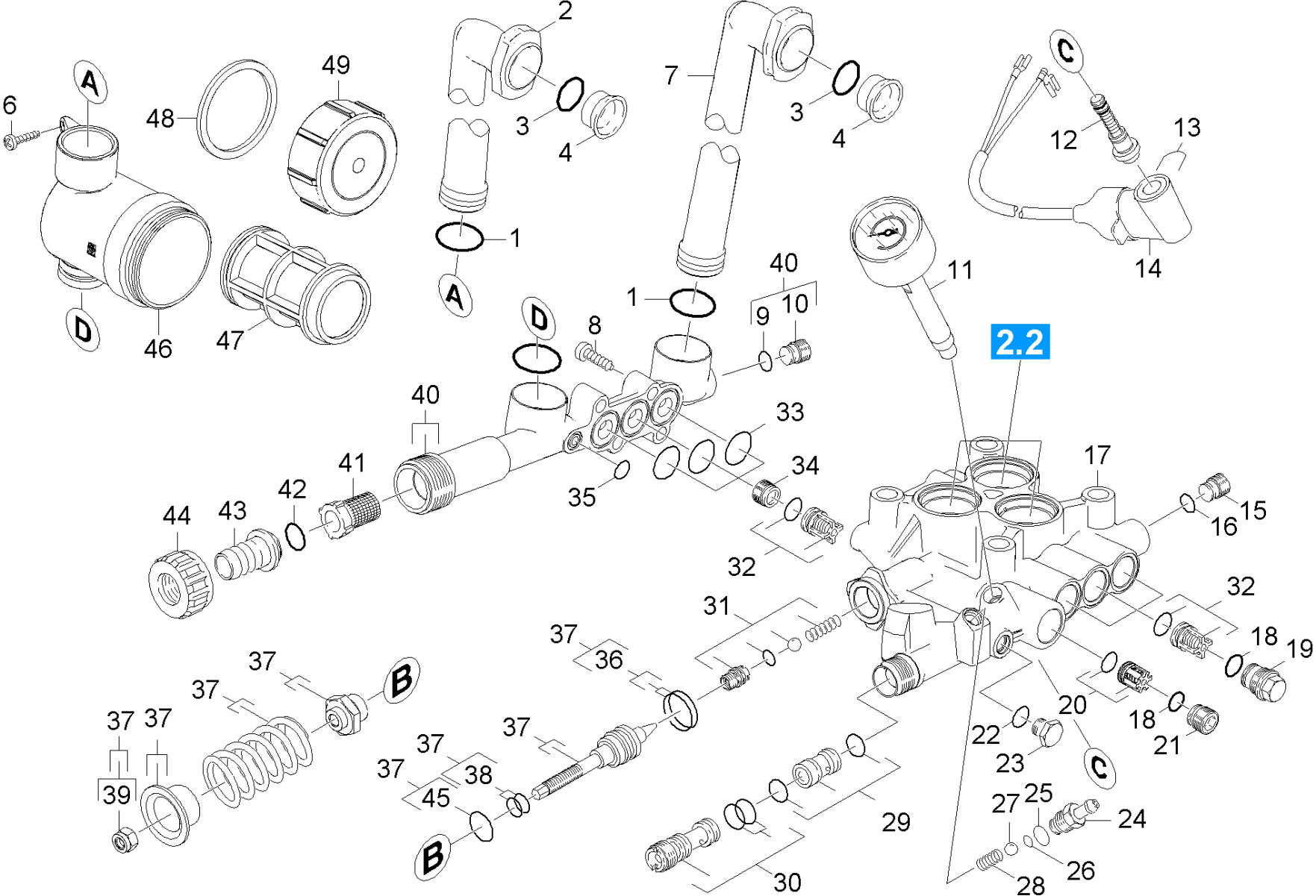

21 Cylinder head

ET/VT (spare/wear parts)	Pos	Material #	Name	Qty.	Unit	from ser.nr.	up to ser.nr.
X-X	1	6.362-686.0	O-Ring seal 20,0 X 3,0	3.000	ST	0000000000	0000000000
	2	5.427-307.0	Manifold	1.000	ST	0000000000	0000000000
X-X	3	6.362-579.0	O-Ring seal 17,5 X 3,5	2.000	ST	0000000000	0000000000
	4	5.110-341.0	Sleeve	2.000	ST	0000000000	0000000000
	6	6.303-153.0	Screw M5x15-ST-R2R (IN6RD)	1.000	ST	0000000000	0000000000
X-X	7	5.427-298.0	Manifold short	1.000	ST	0000000000	0000000000
	8	7.306-043.0	Cylinder head screw M8x30 -8.8-A2E ISO	4.000	ST	0000000000	0000000000
	9	6.362-528.0	O-Ring seal 9,5 X 2,0	1.000	ST	0000000000	0000000000
	10	5.411-168.0	Valve screw M16x1	1.000	ST	0000000000	0000000000
X-X	11	4.423-024.0	Pressure gauge complete	1.000	ST	0000000000	0000000000
X-X	12	2.883-988.0	SPARE PARTS SET	1.000	ST	0000000000	0000000000
	13	5.034-494.0	Retaining bracket	1.000	ST	0000000000	0000000000
X-X	14	4.744-242.0	Switch kpl. -nur für Ersatz-	1.000	ST	0000000000	0000000000
	15	5.411-152.0	Screw plug	1.000	ST	0000000000	0000000000
	16	6.362-384.0	O-Ring seal 9x1,5 - NBR 70	1.000	ST	0000000000	0000000000
X-X	17	4.550-945.0	Cylinder head -nur fuer Ersatz-	1.000	ST	0000000000	0000000000
X-X	18	6.362-481.0	O-Ring seal 14,0 x 2,0 NBR 80	4.000	ST	0000000000	0000000000
	19	5.583-146.0	Valve screw	3.000	ST	0000000000	0000000000
X-X	20	4.580-594.0	Valve complete	1.000	ST	0000000000	0000000000
X-X	21	5.411-166.0	CLOSING SCREW	1.000	ST	0000000000	0000000000
	22	6.362-690.0	O-Ring seal 7x2 - NBR 70	1.000	ST	0000000000	0000000000
	23	5.411-070.0	Screw plug	1.000	ST	0000000000	0000000000
	24	5.443-624.0	Nipple	1.000	ST	0000000000	0000000000
	25	6.362-113.0	O-Ring seal 6,0 x 2,0 NBR 70	1.000	ST	0000000000	0000000000
	26	6.362-175.0	O-Ring seal 5,28x 1,78	1.000	ST	0000000000	0000000000

21 Cylinder head

ET/VT (spare/wear parts)	Pos	Material #	Name	Qty.	Unit	from ser.nr.	up to ser.nr.
	27	7.401-908.0	Sphere 7 G300 -1.4301 DIN 5401	1.000	ST	0000000000	0000000000
	28	5.332-258.0	Helical spring	1.000	ST	0000000000	0000000000
	29	2.884-853.0	Spare part set nozzle insert	1.000	ST	0000000000	0000000000
X	30	4.769-026.0	Nozzle insert	1.000	ST	0000000000	0000000000
X-X	31	4.481-226.0	Valve seat complete	1.000	ST	0000000000	0000000000
X-X	32	2.884-512.0	Valve (3 Stueck)	2.000	ST	0000000000	0000000000
X-X	33	6.362-547.0	O-Ring seal 20,0x1,5-NBR 70	3.000	ST	0000000000	0000000000
	34	5.583-177.0	Valve screw M20x1	3.000	ST	0000000000	0000000000
	35	6.362-388.0	O-Ring seal 8,0x1,5 -EPDM 70	1.000	ST	0000000000	0000000000
X-X	36	6.362-575.0	O-Ring seal 12,42 KOMPL	1.000	ST	0000000000	0000000000
X-X	37	4.591-056.0	Set excess-current	1.000	ST	0000000000	0000000000
X-X	38	6.362-365.0	O-Ring seal complete 1ST.-R.- 7,65X 1,7	1.000	ST	0000000000	0000000000
	39	7.311-510.0	Hexagon nut M 8-8-A2E ISO 7040	1.000	ST	0000000000	0000000000
	40	4.427-310.0	Manifold complete	1.000	ST	0000000000	0000000000
X	41	6.414-141.0	Strainer	1.000	ST	0000000000	0000000000
	42	6.362-161.0	O-Ring seal 19,3 X 2,4	1.000	ST	0000000000	0000000000
	43	5.443-291.0	Hose stem	1.000	ST	0000000000	0000000000
	44	5.310-076.0	Nut	1.000	ST	0000000000	0000000000
	45	6.362-381.0	O-Ring seal 13x2 - NBR 70	1.000	ST	0000000000	0000000000
	46	5.605-348.0	Filter housing	1.000	ST		
	47	6.414-949.0	Filter cartridge	1.000	ST		
X	48	5.363-613.0	Seal	1.000	ST		
X	49	5.064-453.0	Cover qusty grey	1.000	ST		

11 Pressure gauge complete (4.423-024.0)

Pos	Material #	Name	Qty.	Unit
3	6.376-036.0	Label spare parts neutrally 65x55 MM	2.000	ZST

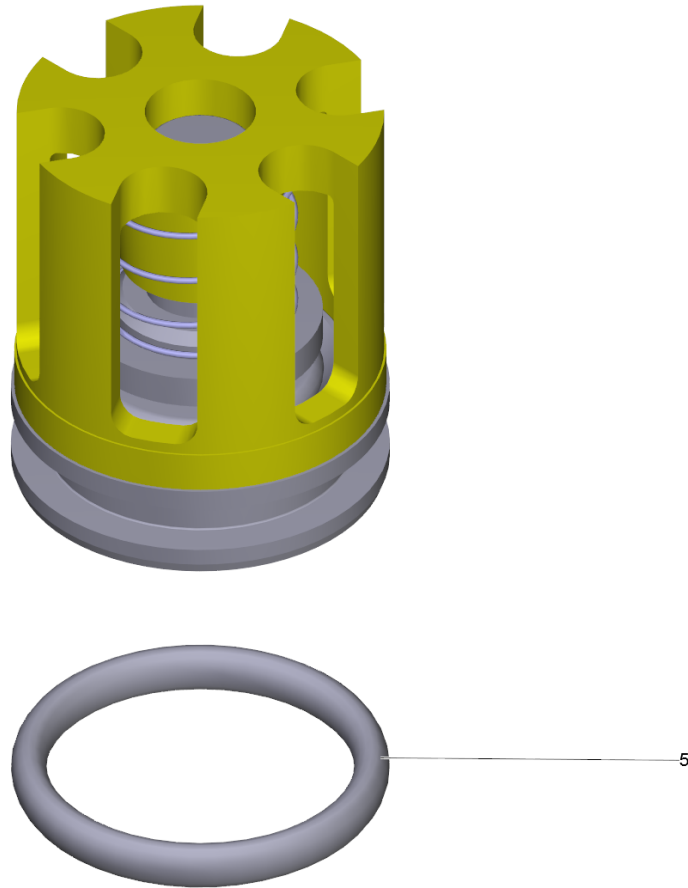

20 Valve complete (4.580-594.0)

Pos	Material #	Name	Qty.	Unit
5	6.362-381.0	O-Ring seal 13x2 - NBR 70	1.000	ST

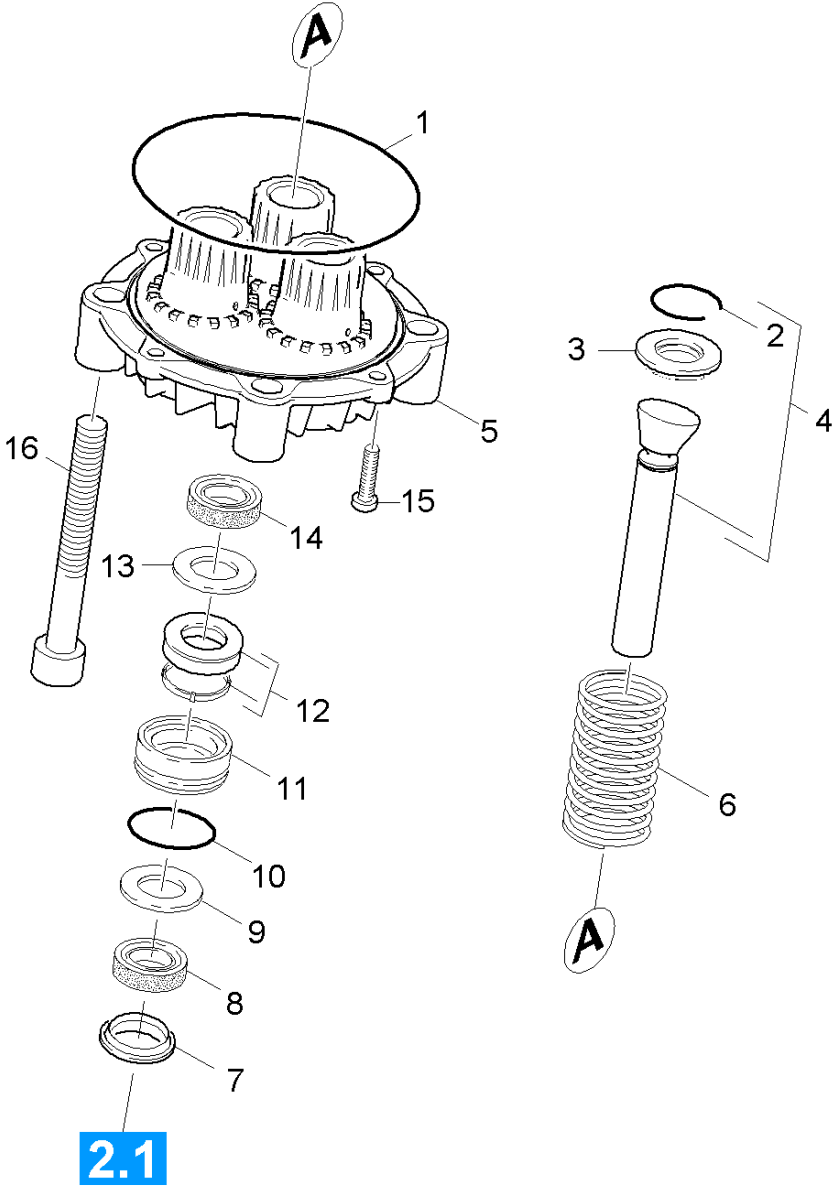

2.1

22 Thrust guidance

ET/VT (spare/wear parts)	Pos	Material #	Name	Qty.	Unit	from ser.nr.	up to ser.nr.
X-X	1	6.362-613.0	O-Ring seal 101,27X 2,62-NBR 70	1.000	ST	0000000000	0000000000
	2	6.472-331.0	Snap ring 20	3.000	ST	0000000000	0000000000
X	3	5.116-310.0	Washer	3.000	ST	0000000000	0000000000
X-X	4	4.553-279.0	Piston complete	3.000	ST	0000000000	0000000000
	5	5.061-185.0	Thrust guidance	1.000	ST	0000000000	0000000000
X-X	6	5.332-550.0	Helical spring	3.000	ST	0000000000	0000000000
X-X	7	6.365-378.0	Supportring 20x30x4,2	3.000	ST	0000000000	0000000000
X-X	8	6.365-377.0	Grooved ring 20x30x6	3.000	ST	0000000000	0000000000
X-X	9	5.115-538.0	Washer	3.000	ST	0000000000	0000000000
X-X	10	6.362-406.0	O-Ring seal 33,05X 1,78-NBR 70	3.000	ST	0000000000	0000000000
X-X	11	5.112-778.0	Bush	3.000	ST	0000000000	0000000000
X-X	12	6.365-380.0	Set of gaskets low-pressure	3.000	ST	0000000000	0000000000
X-X	13	5.115-255.0	Washer	3.000	ST	0000000000	0000000000
X-X	14	6.365-052.0	Grooved ring 20X28X6/8	3.000	ST	0000000000	0000000000
	15	7.306-092.0	Screw M6x20-ST- 8.8-R3R (IN6RD)	2.000	ST	0000000000	0000000000
	16	7.306-155.0	Cylinder head screw M12x100 -8.8-A3E IS	4.000	ST	0000000000	0000000000

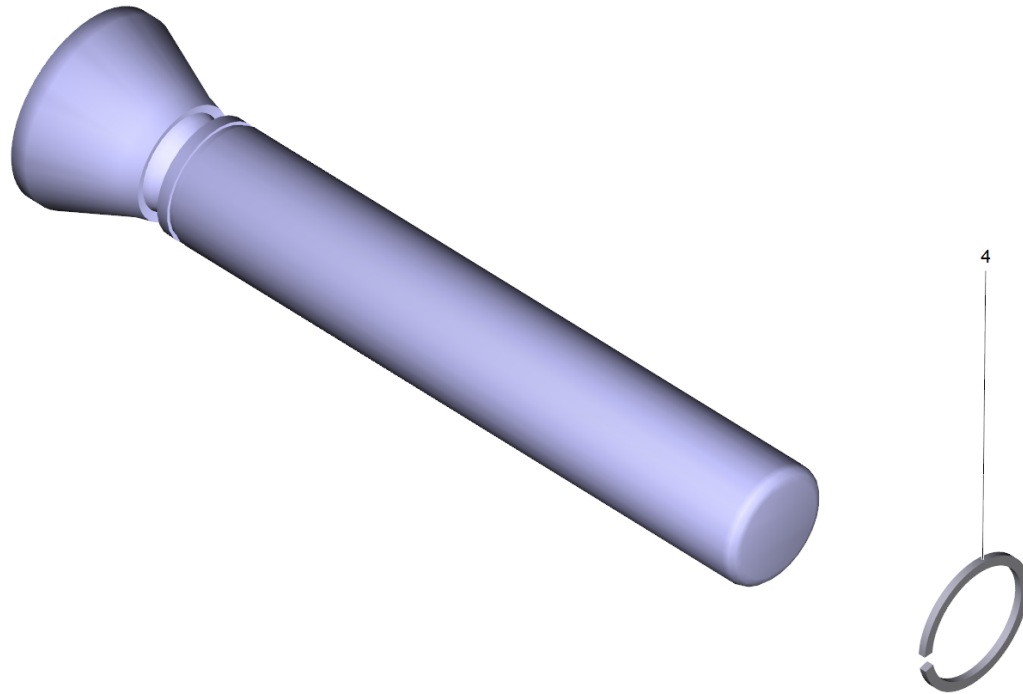

4 Piston complete (4.553-279.0)

Pos	Material #	Name	Qty.	Unit
4	6.472-331.0	Snap ring 20	1.000	ST

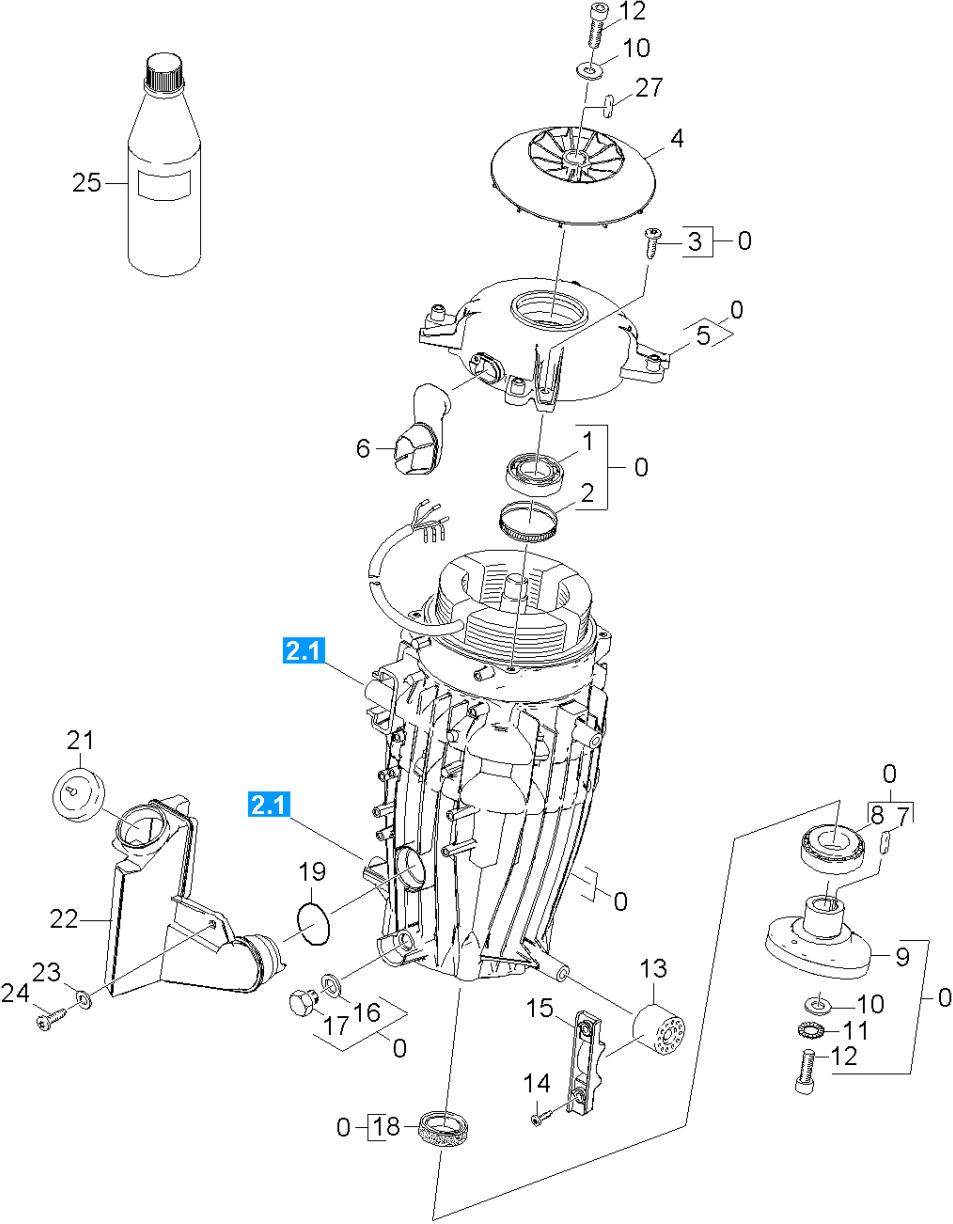

30 Motor

ET/VT (spare/wear parts)	Pos	Material #	Name	Qty.	Unit	from ser.nr.	up to ser.nr.
	0	4.623-871.0	Motor complete only for replacement	1.000	ST		
	1	6.401-253.0	Ball bearing 6305-2Z	1.000	ST	0000000000	0000000000
	2	6.343-010.0	Tolerance ring 62x10	1.000	ST	0000000000	0000000000
	3	7.303-049.0	Screw M6x25-ST-A3R (IN6RD)	4.000	ST	0000000000	0000000000
	4	5.600-082.0	Blower wheel	1.000	ST	0000000000	0000000000
	5	5.061-186.0	Bearing cover B	1.000	ST	0000000000	0000000000
	6	5.365-270.0	Profile gasket	1.000	ST	0000000000	0000000000
	7	7.318-030.0	Parallel key 6x6x25 -C45R DIN 6885-1	1.000	ST	0000000000	0000000000
	8	6.401-405.0	Taper roller bearing	1.000	ST	0000000000	0000000000
	9	4.120-239.0	Wobble plate -nur für Ersatz-	1.000	ST	0000000000	0000000000
	10	5.115-565.0	Washer	2.000	ST	0000000000	0000000000
	11	7.312-159.0	Toothed lock washer A8,4-FST-PH DIN 679	1.000	ST	0000000000	0000000000
	12	7.306-041.0	Cylinder head screw M8x20 -8.8-A2E ISO	2.000	ST	0000000000	0000000000
	13	5.767-005.0	Rubber buffer	4.000	ST	0000000000	0000000000
	14	7.303-108.0	Screw 5x20 -10.9-R2R (In6Rd)	4.000	ST	0000000000	0000000000
	15	5.802-288.0	Mounting part	2.000	ST	0000000000	0000000000
	16	6.362-028.0	O-Ring seal 11x2,2 NBR 70	2.000	ST	0000000000	0000000000
	17	5.411-100.0	Screw plug	2.000	ST	0000000000	0000000000
	18	7.367-009.0	Radial shaft seal ring A35x52x7-NBR DIN	2.000	ST	0000000000	0000000000
	19	6.362-722.0	O-Ring seal 28,0 X 3,0	1.000	ST	0000000000	0000000000
X-X	21	5.064-457.0	Cover qusty grey SAE 90	1.000	ST	0000000000	0000000000
	22	5.070-658.0	Tank oil	1.000	ST	0000000000	0000000000
	23	7.312-260.0	Washer 6 -100HV-A3E ISO 7094	1.000	ST	0000000000	0000000000
	24	6.303-153.0	Screw M5x15-ST-R2R (IN6RD)	1.000	ST	0000000000	0000000000
X-X	25	6.288-016.0	Gear oil 1L	1.000	ST	0000000000	0000000000

30 Motor

ET/VT (spare/wear parts)	Pos	Material #	Name	Qty.	Unit	from ser.nr.	up to ser.nr.
	27	7.318-079.0	Parallel key A 5x5x25-C45R DIN 6885	1.000	ST	0000000000	0000000000

40 Accessories

Pos	Name	Qty.	Unit
41	Hand trigger gun	1.000	ST
42	Rotary controller	1.000	ST
43	High pressure hose	1.000	ST
44	Jet pipe	1.000	ST
45	Triple jet nozzle	1.000	ST

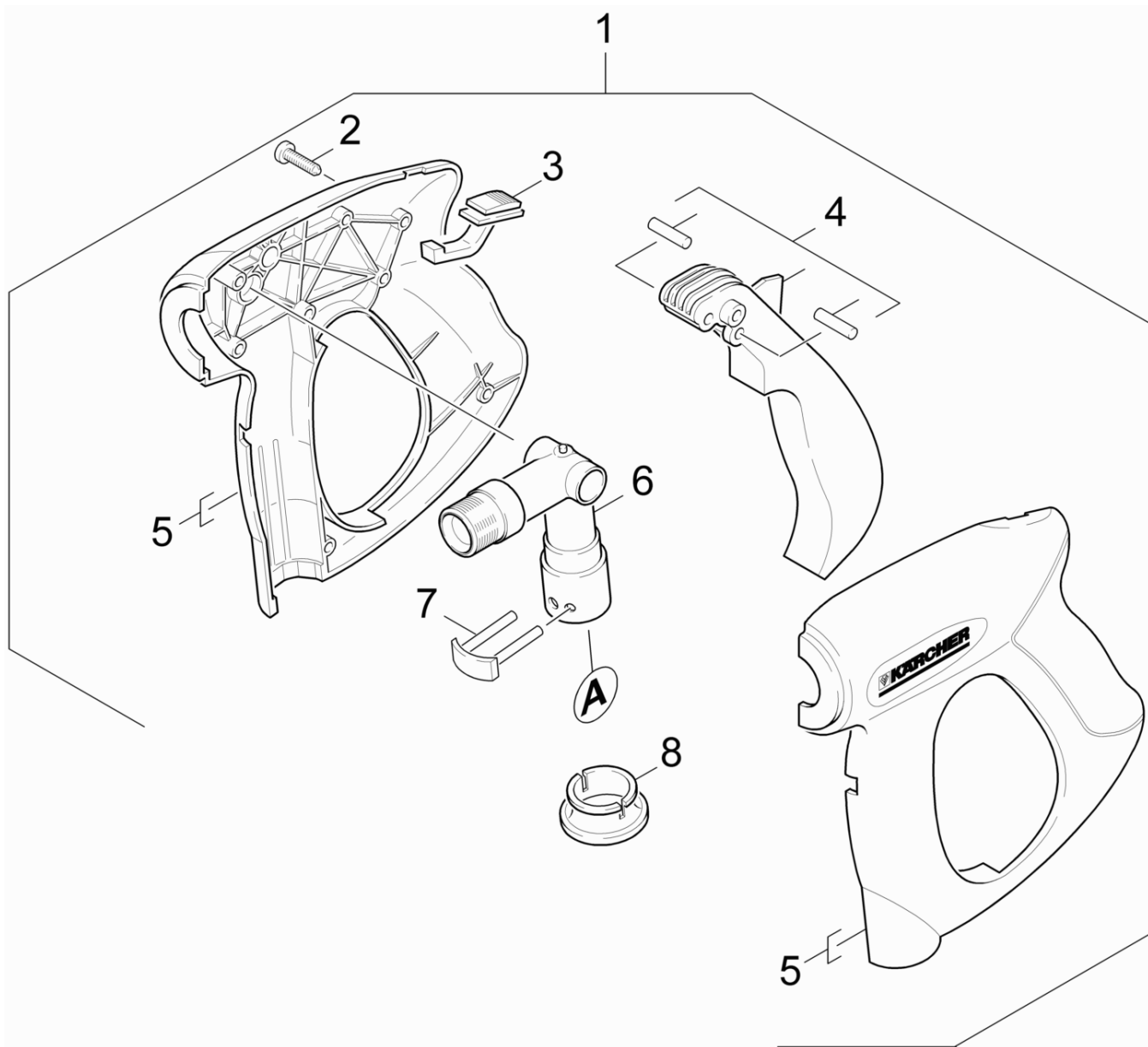

41 Hand trigger gun

ET/VT (spare/wear parts)	Pos	Material #	Name	Qty.	Unit
X-X	1	4.775-463.0	HAND TRIGGER GUN EASY PRESS	1.000	ST
	2	7.303-096.0	Screw 4x22 -ST-10.9-R2R (IN6RD)	7.000	ST
	3	5.481-331.0	Slider	1.000	ST
	4	4.481-209.0	Lever complete	1.000	ST
	5	5.321-669.0	Handhold few	1.000	ST
X	6	4.427-215.0	Manifold complete only for replacement	1.000	ST
X	7	4.037-013.0	Hook	1.000	ST
	8	5.110-596.0	Sleeve	1.000	ST

1 HAND TRIGGER GUN EASY PRESS (4.775-463.0)

ET/VT (spare/wear parts)	Pos	Material #	Name	Qty.	Unit
X	2	4.037-013.0	Hook	1.000	ST
	3	6.368-012.0	Protecting cap 22X1,5	1.000	ST
	4	6.869-075.0	Metal bonding agent 1 ml	1.000	ST
	25	5.110-596.0	Sleeve	1.000	ST
	32	5.321-669.0	Handhold few	1.000	ST
	34	5.481-331.0	Slider	1.000	ST
	41	6.288-028.0	Silicon grease	1.000	ZST
	45	7.303-096.0	Screw 4x22 -ST-10.9-R2R (IN6RD)	7.000	ST
	49	5.314-119.0	Pin	2.000	ST
	55	6.363-331.0	O-Ring seal 9,0 x 1,5	1.000	ST
	57	6.363-330.0	O-Ring seal 2,9 x 1,78	1.000	ST
	101	6.376-020.0	Label 65X55 MM	1.000	ZST
	510	6.286-058.0	Adhesiv cloth tape PE 50mm x 66 m transp	0.140	M
	520		Wooden pallet EURO-POOL	0.005	ZST
	999	4.481-209.0	Lever complete	1.000	ST
X	999	4.427-215.0	Manifold complete only for replacement	1.000	ST

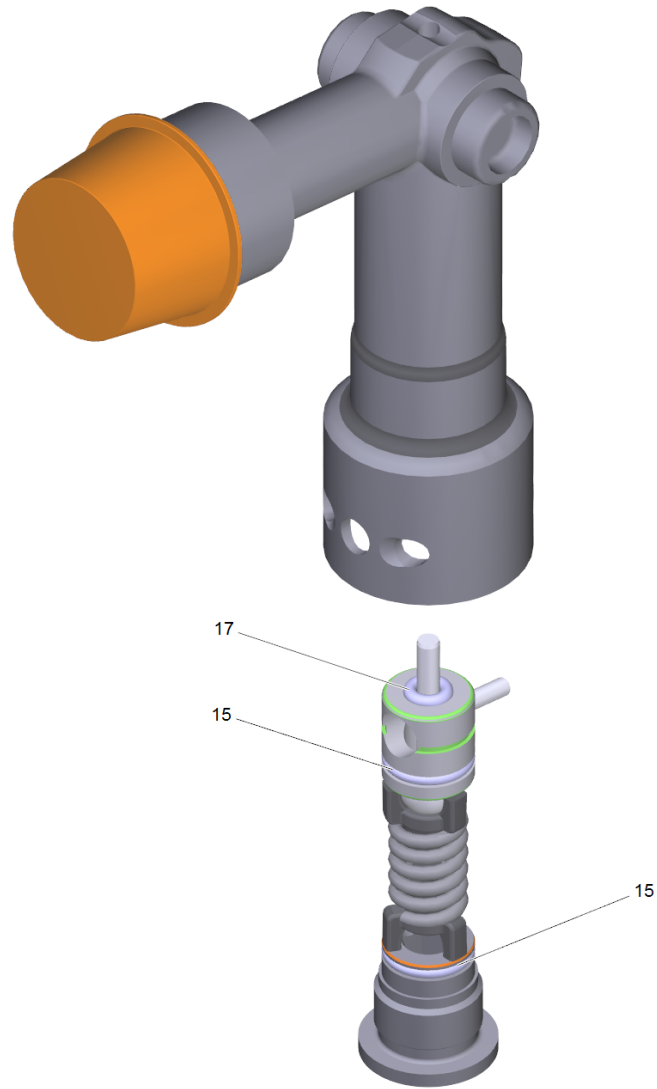

999 Manifold complete only for replacement (4.427-215.0)

Pos	Material #	Name	Qty.	Unit
15	6.363-331.0	O-Ring seal 9,0 x 1,5	2.000	ST
17	6.363-330.0	O-Ring seal 2,9 x 1,78	1.000	ST

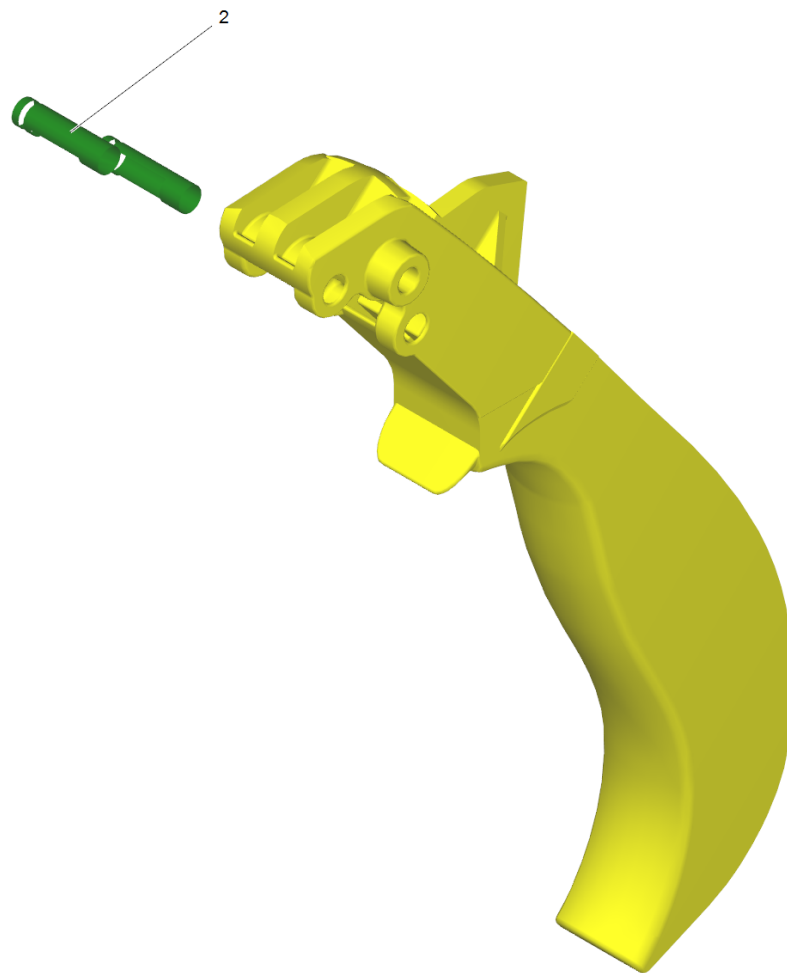

999 Lever complete (4.481-209.0)

Pos	Material #	Name	Qty.	Unit
2	5.314-119.0	Pin	2.000	ST

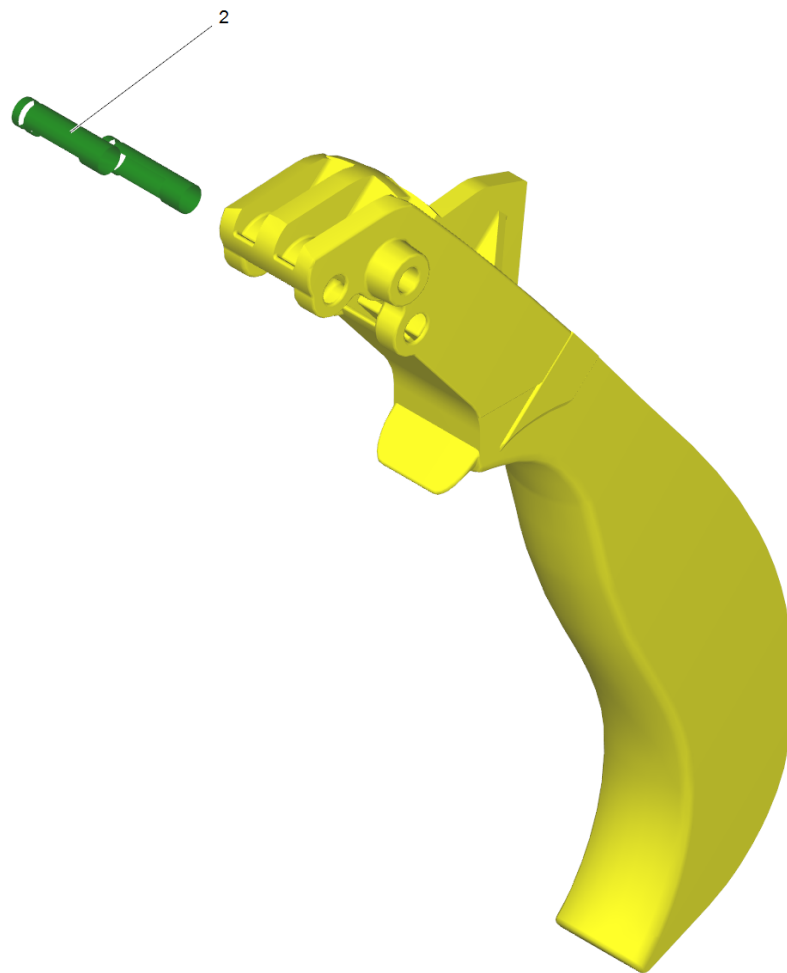

4 Lever complete (4.481-209.0)

Pos	Material #	Name	Qty.	Unit
2	5.314-119.0	Pin	2.000	ST

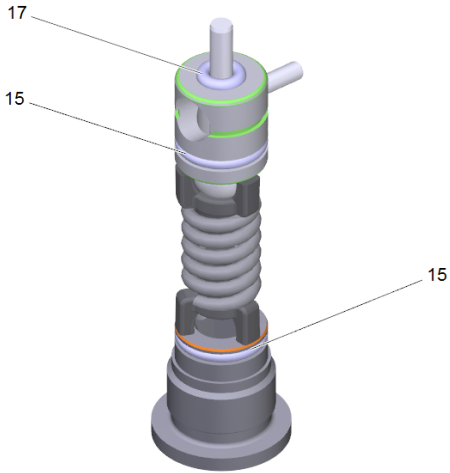
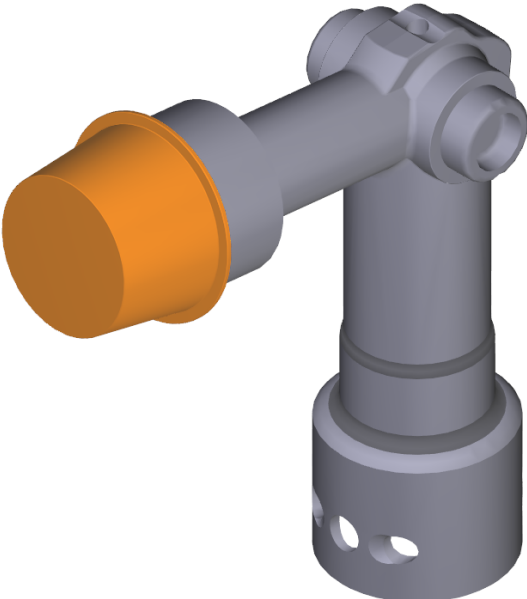

6 Manifold complete only for replacement (4.427-215.0)

Pos	Material #	Name	Qty.	Unit
15	6.363-331.0	O-Ring seal 9,0 x 1,5	2.000	ST
17	6.363-330.0	O-Ring seal 2,9 x 1,78	1.000	ST

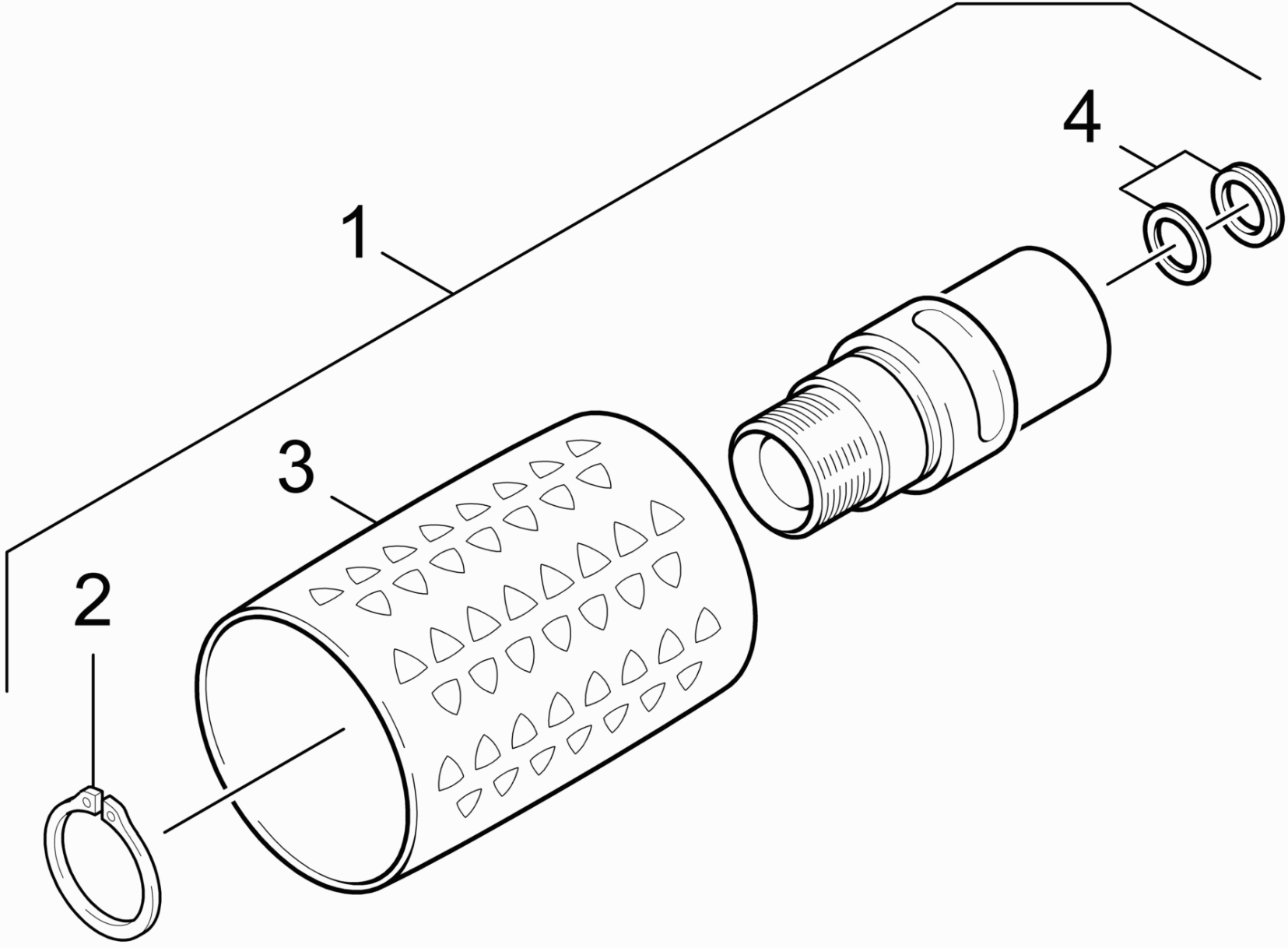

42 Rotary controller

ET/VT (spare/wear parts)	Pos	Material #	Name	Qty.	Unit
X-X	1	4.775-470.0	Rotary controller 416L	1.000	ST
	2	7.343-008.0	Locking ring 25x1,2-St-vz DIN 471	1.000	ST
	3	5.321-668.0	Handle	1.000	ST
X-X	4	4.363-695.0	Grooved ring only for replacement	1.000	ST

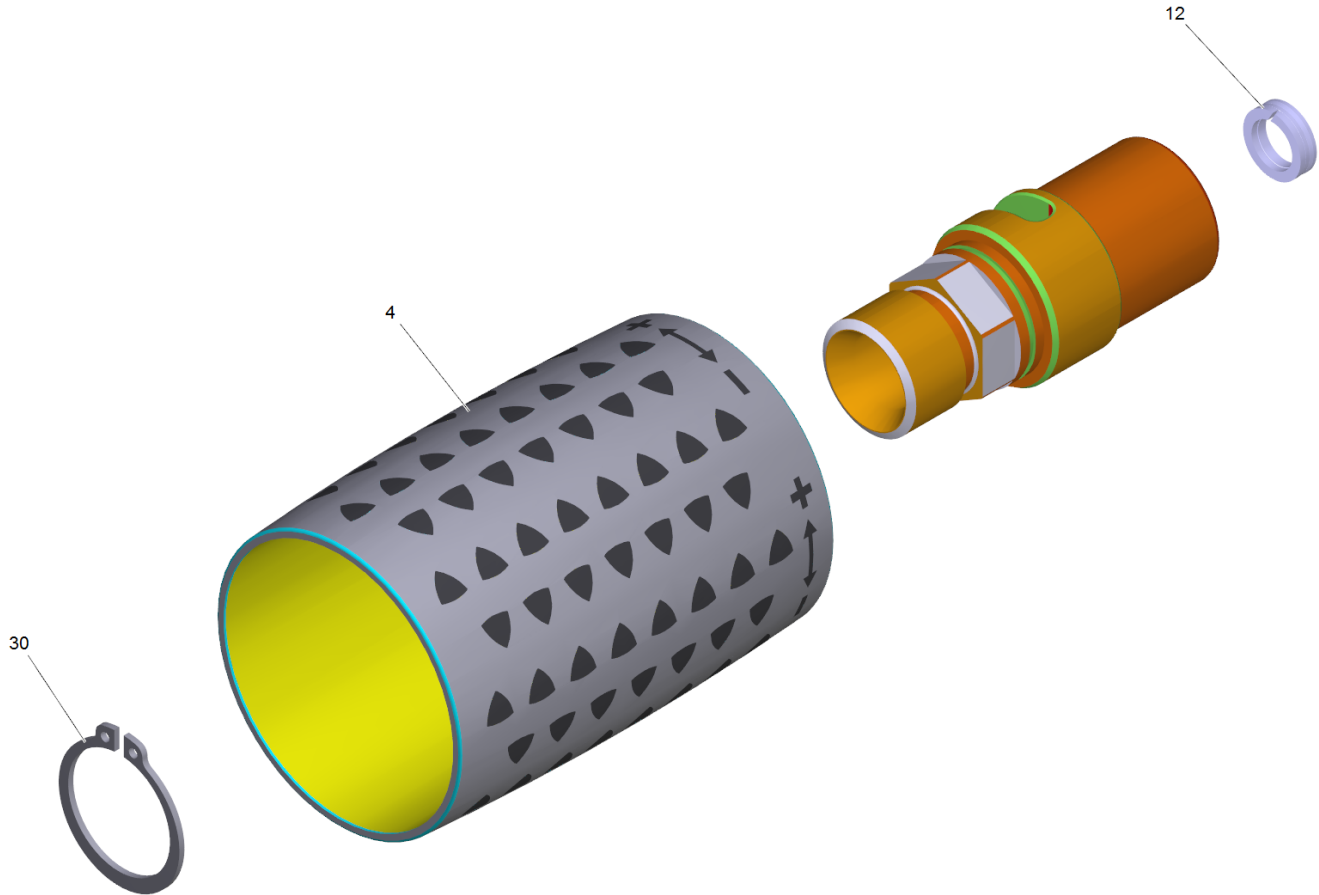

1 Rotary controller 416L (4.775-470.0)

ET/VT (spare/wear parts)	Pos	Material #	Name	Qty.	Unit
	4	5.321-668.0	Handle	1.000	ST
X-X	12	4.363-695.0	Grooved ring only for replacement	1.000	ST
	30	7.343-008.0	Locking ring 25x1,2-St-vz DIN 471	1.000	ST

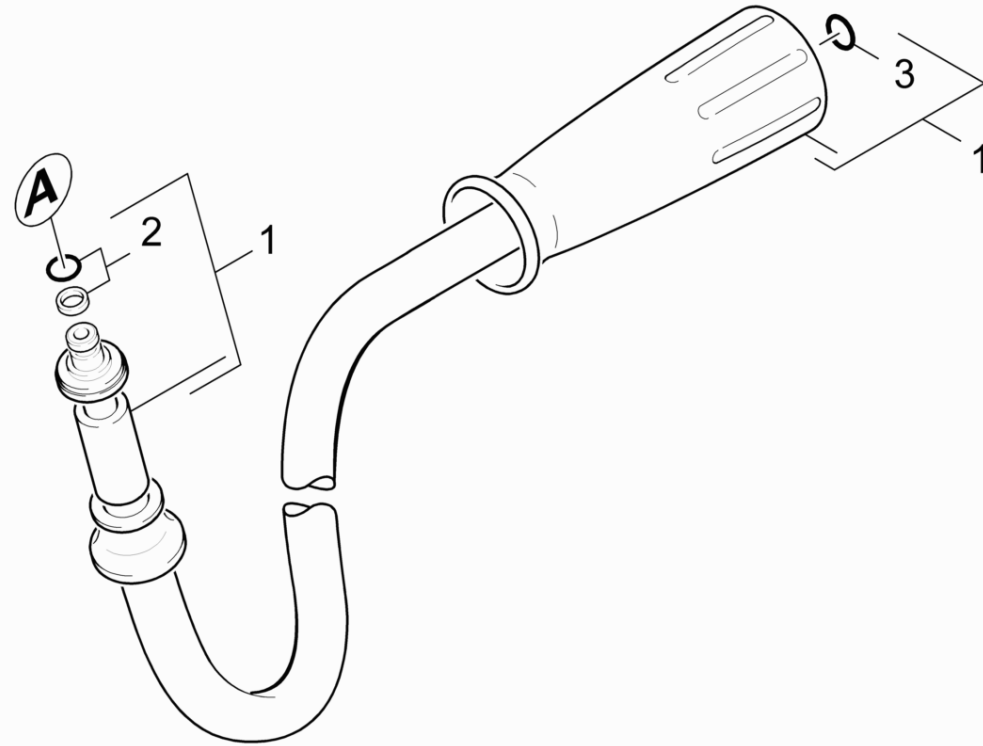

43 High pressure hose

ET/VT (spare/wear parts)	Pos	Material #	Name	Qty.	Unit
X-X	1	6.390-025.0	Hose assembly DN8 max.31,5MPa 10m	1.000	ST
X-X	2	4.363-691.0	O-Ring seal kpl. -nur fuer Ersatz-	1.000	ST
	3	2.880-990.0	Spare part set O-Ring 5x -Kaercher	1.000	ST

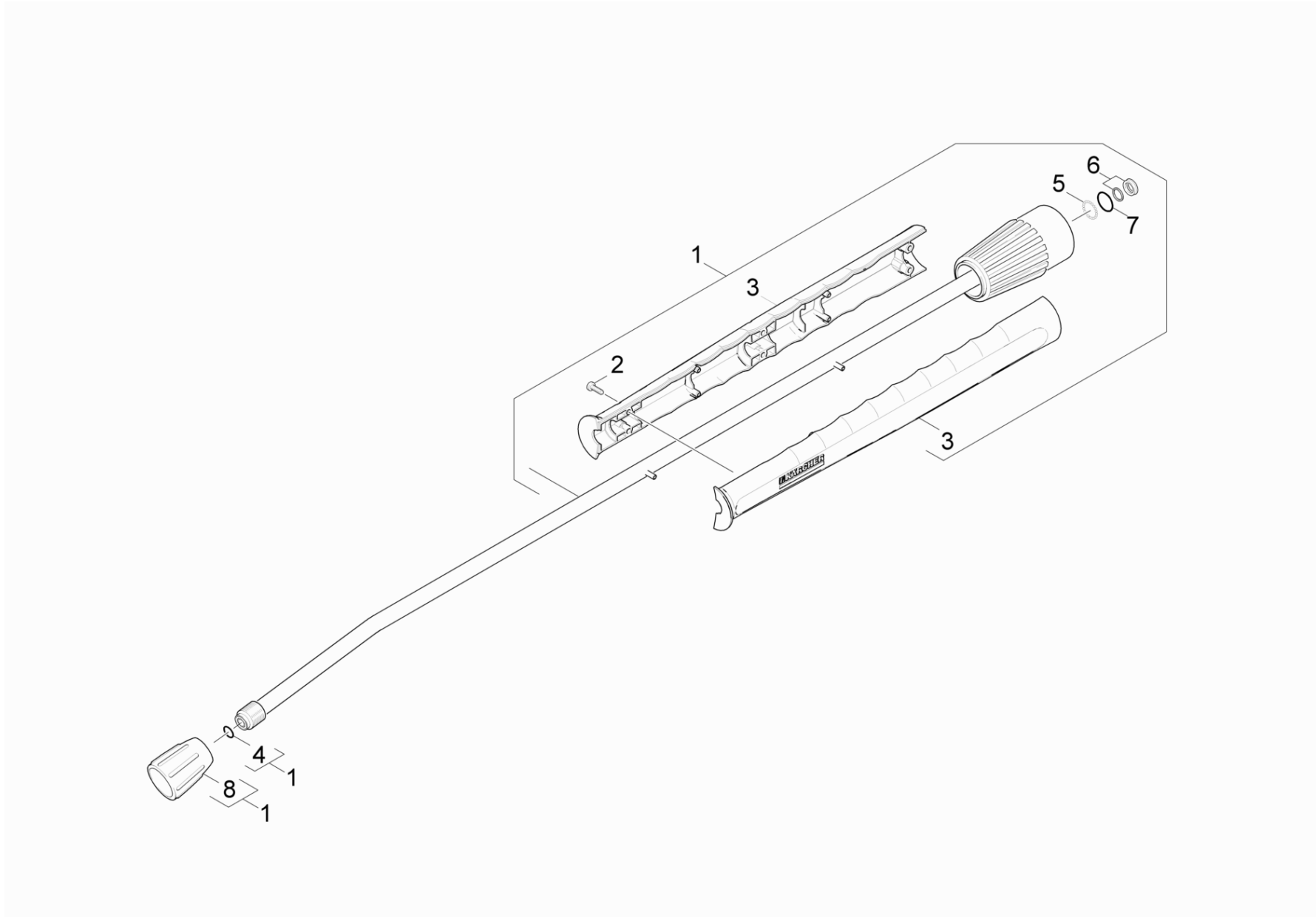

44 Jet pipe

ET/VT (spare/wear parts)	Pos	Material #	Name	Qty.	Unit	from ser.nr.	up to ser.nr.
X-X	1	4.760-660.0	Jet pipe packaged only for replacement	1.000	ST	0000000000	0000000000
	2	7.303-129.0	Screw 4x16 -10.9-R2R (K-In6Rd)	6.000	ST	0000000000	0000000000
	3	5.321-855.0	Handhold few jet pipe with welding bolt	1.000	ST		
	4	2.880-990.0	Spare part set O-Ring 5x -Kaercher	1.000	ST	0000000000	0000000000
X-X	5	7.401-915.0	Sphere 2,5 G20 -1.4034 DIN 5401	20.000	ST	0000000000	0000000000
X-X	6	4.363-692.0	Grooved ring kpl. -nur fuer Ersatz-	1.000	ST	0000000000	0000000000
	7	6.362-524.0	O-Ring seal 17,0 X 1,5	1.000	ST	0000000000	0000000000
X-X	8	5.401-210.0	Screw connector part	1.000	ST	0000000000	0000000000

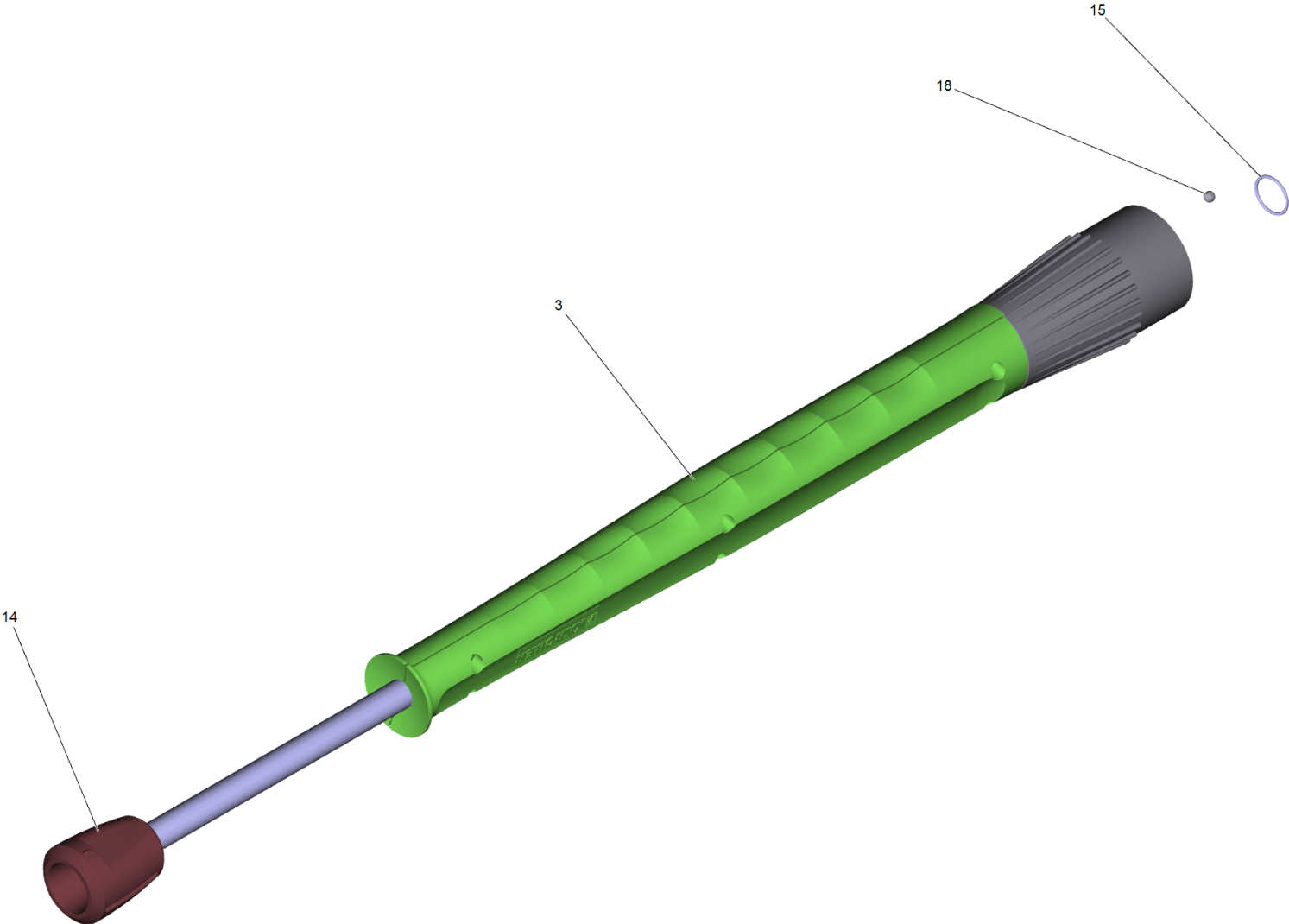

1 Jet pipe packaged only for replacement (4.760-660.0)

ET/VT (spare/wear parts)	Pos	Material #	Name	Qty.	Unit
	3	5.321-855.0	Handhold few jet pipe with welding bolt	1.000	ST
X-X	14	5.401-210.0	Screw connector part	1.000	ST
	15	7.362-501.0	O-Ring seal 10x2 EPDM 70 DIN 3770	1.000	ST
X-X	18	7.401-915.0	Sphere 2,5 G20 -1.4034 DIN 5401	1.000	ST

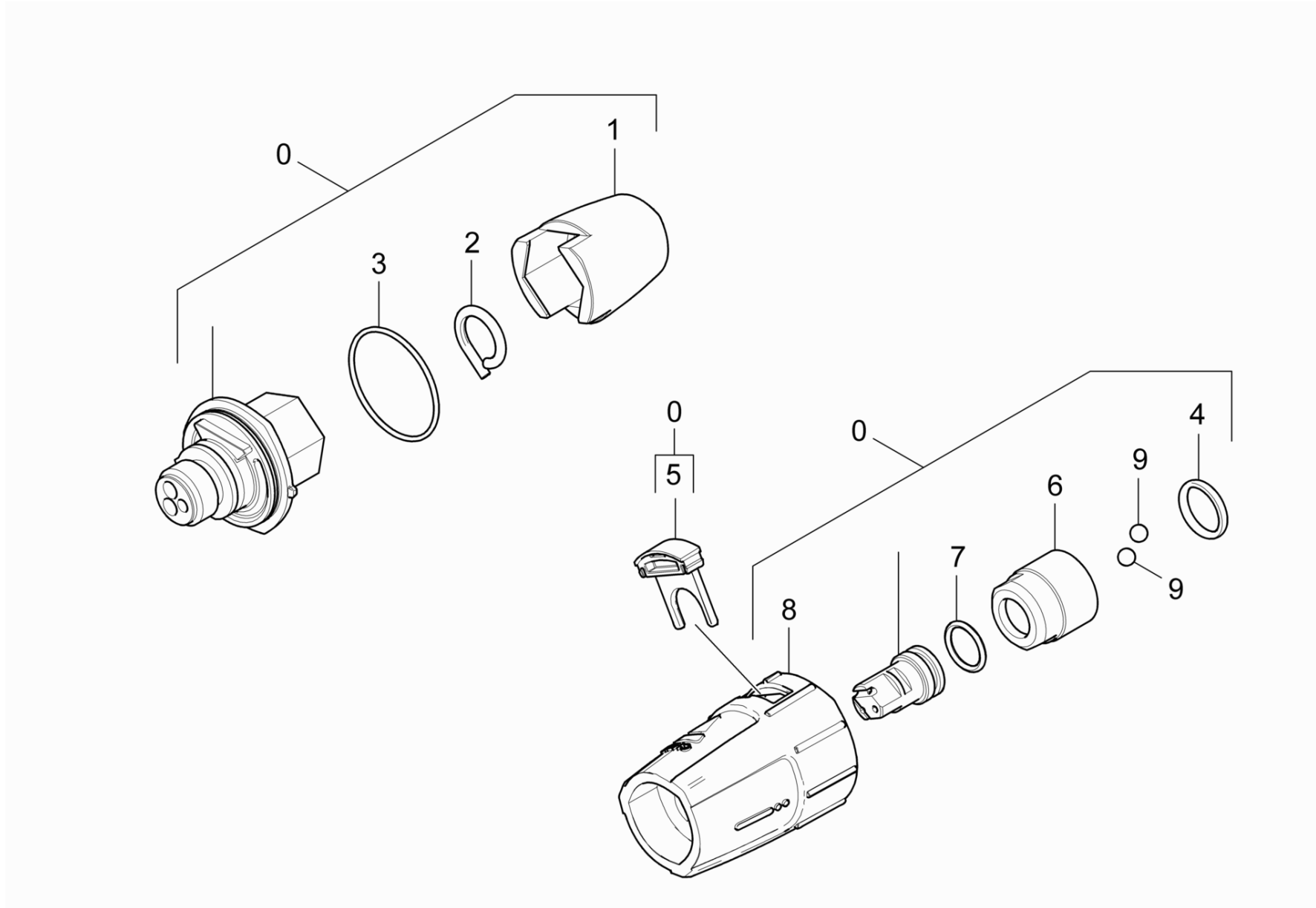

45 Triple jet nozzle

ET/VT (spare/wear parts)	Pos	Material #	Name	Qty.	Unit
X-X	0	4.767-154.0	Triple jet nozzle only for replacement 0	1.000	ST
	1	5.394-530.0	Protection part complete	1.000	ST
	2	6.343-150.0	Pin 03	1.000	ST
	3	6.362-409.0	O-Ring seal 32,0 X 1,5	1.000	ST
	4	6.362-460.0	O-Ring seal 14,0 X 2,5-NBR 70	1.000	ST
	5	5.321-884.0	Clamp	1.000	ST
	6	5.311-225.0	Nut	1.000	ST
	7	6.362-480.0	O-Ring seal 12,42x 1,78	1.000	ST
	8	5.394-859.0	Protection part	1.000	ST
	9	7.401-902.0	Sphere 5 G20 -1.4034 DIN 5401	2.000	ST

0 Triple jet nozzle only for replacement 0 (4.767-154.0)

Pos	Name	Qty.	Unit
2	Spare parts list triple jet nozzle	1.000	ST

2 Spare parts list triple jet nozzle

Pos	Name	Qty.	Unit
10	Triple jet nozzle plastics	1.000	ST
20	Triple jet nozzle brass	1.000	ST

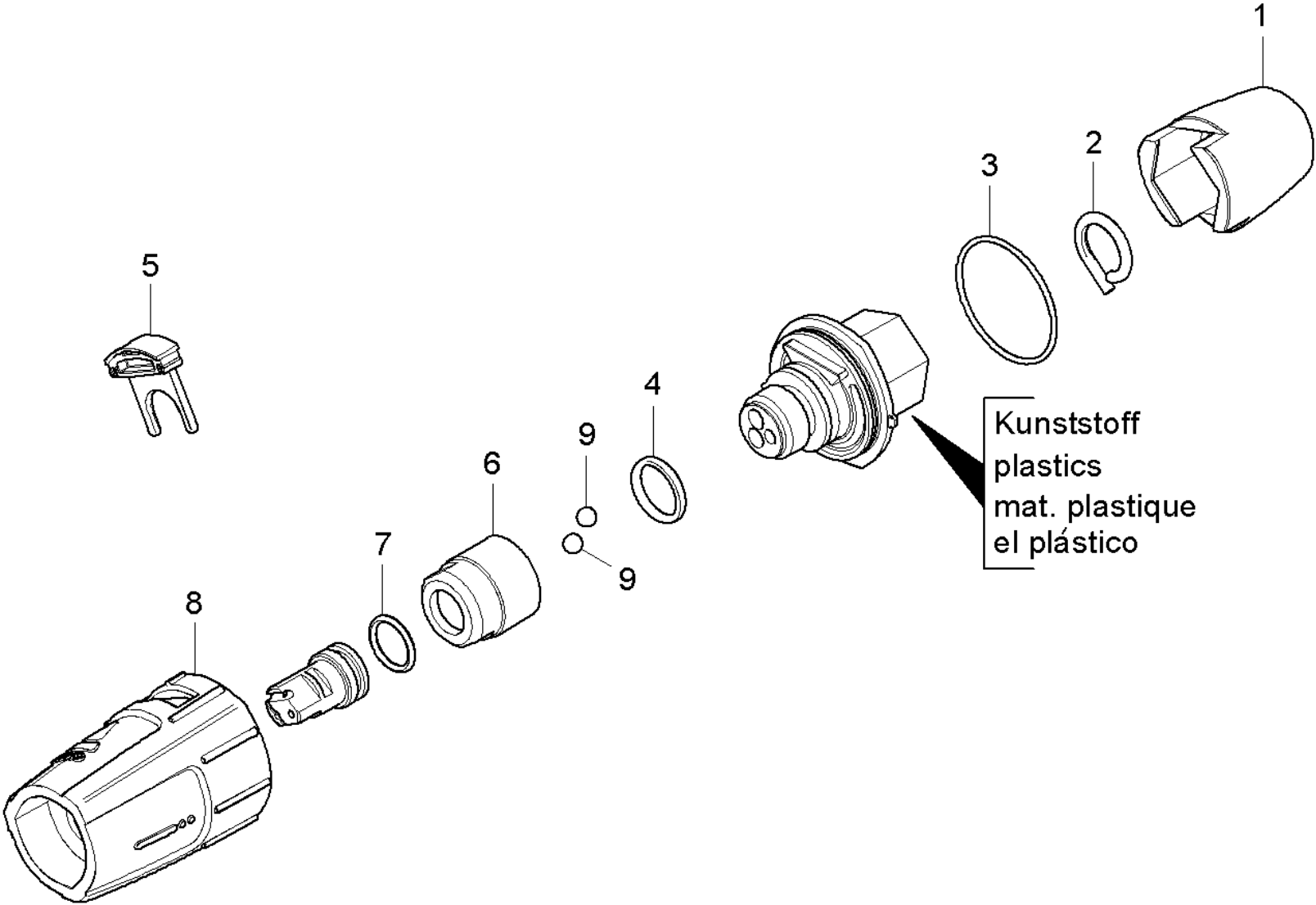

10 Triple jet nozzle plastics

Pos	Material #	Name	Qty.	Unit
1	5.394-530.0	Protection part complete	1.000	ST
2	6.343-150.0	Pin 03	1.000	ST
3	6.362-409.0	O-Ring seal 32,0 X 1,5	1.000	ST
4	7.362-039.0	O-Ring seal 15,5x1,5 -NBR70 DIN 3771	1.000	ST
5	5.321-884.0	Clamp	1.000	ST
6	5.311-236.0	Nut	1.000	ST
7	6.362-480.0	O-Ring seal 12,42x 1,78	1.000	ST
8	5.394-874.0	Protection part	1.000	ST
9	7.401-902.0	Sphere 5 G20 -1.4034 DIN 5401	2.000	ST

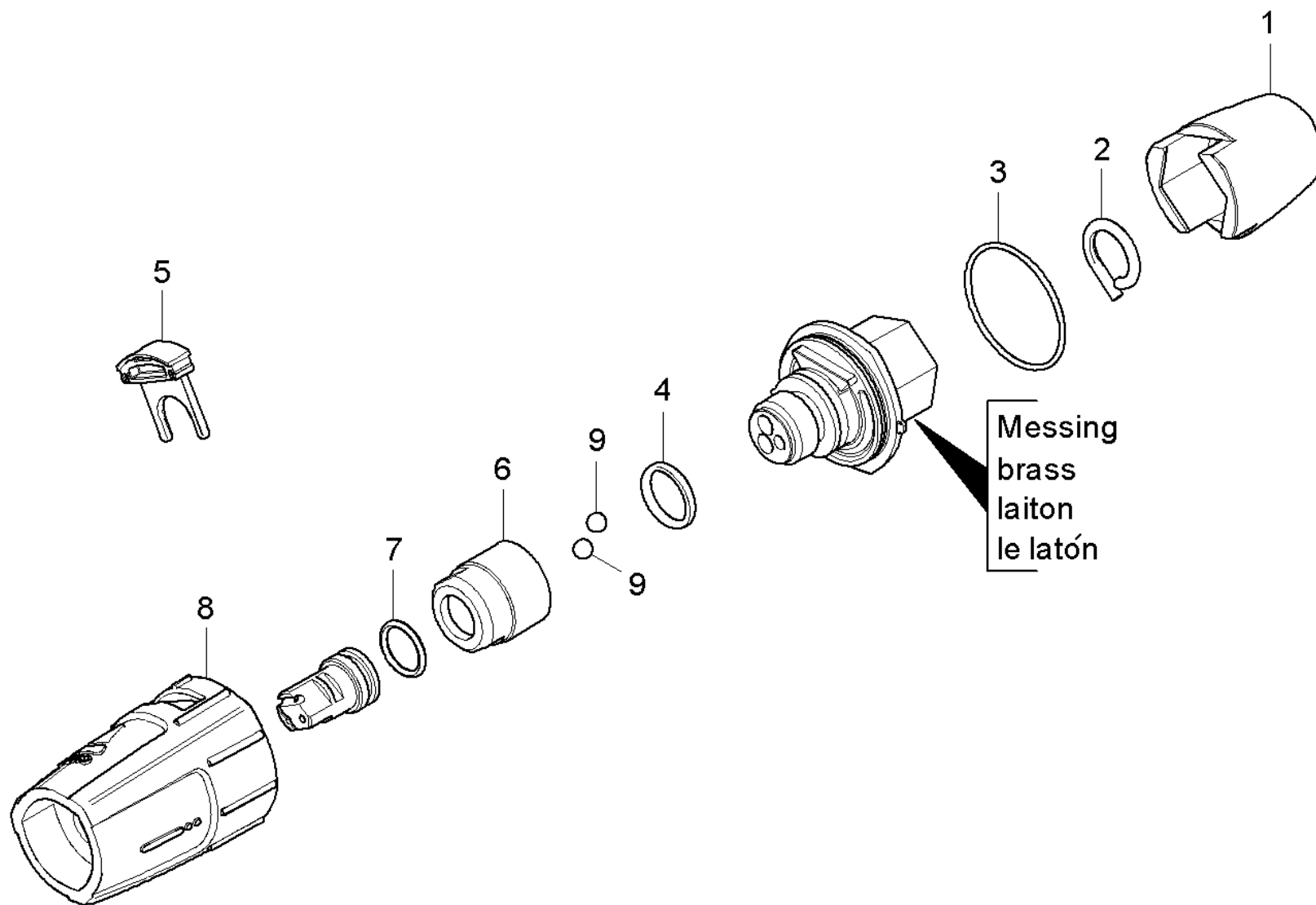

20 Triple jet nozzle brass

Pos	Material #	Name	Qty.	Unit
1	5.394-530.0	Protection part complete	1.000	ST
2	6.343-150.0	Pin 03	1.000	ST
3	6.362-409.0	O-Ring seal 32,0 X 1,5	1.000	ST
4	6.362-460.0	O-Ring seal 14,0 X 2,5-NBR 70	1.000	ST
5	5.321-884.0	Clamp	1.000	ST
6	5.311-225.0	Nut	1.000	ST
7	6.362-480.0	O-Ring seal 12,42x 1,78	1.000	ST
8	5.394-859.0	Protection part	1.000	ST
9	7.401-902.0	Sphere 5 G20 -1.4034 DIN 5401	2.000	ST

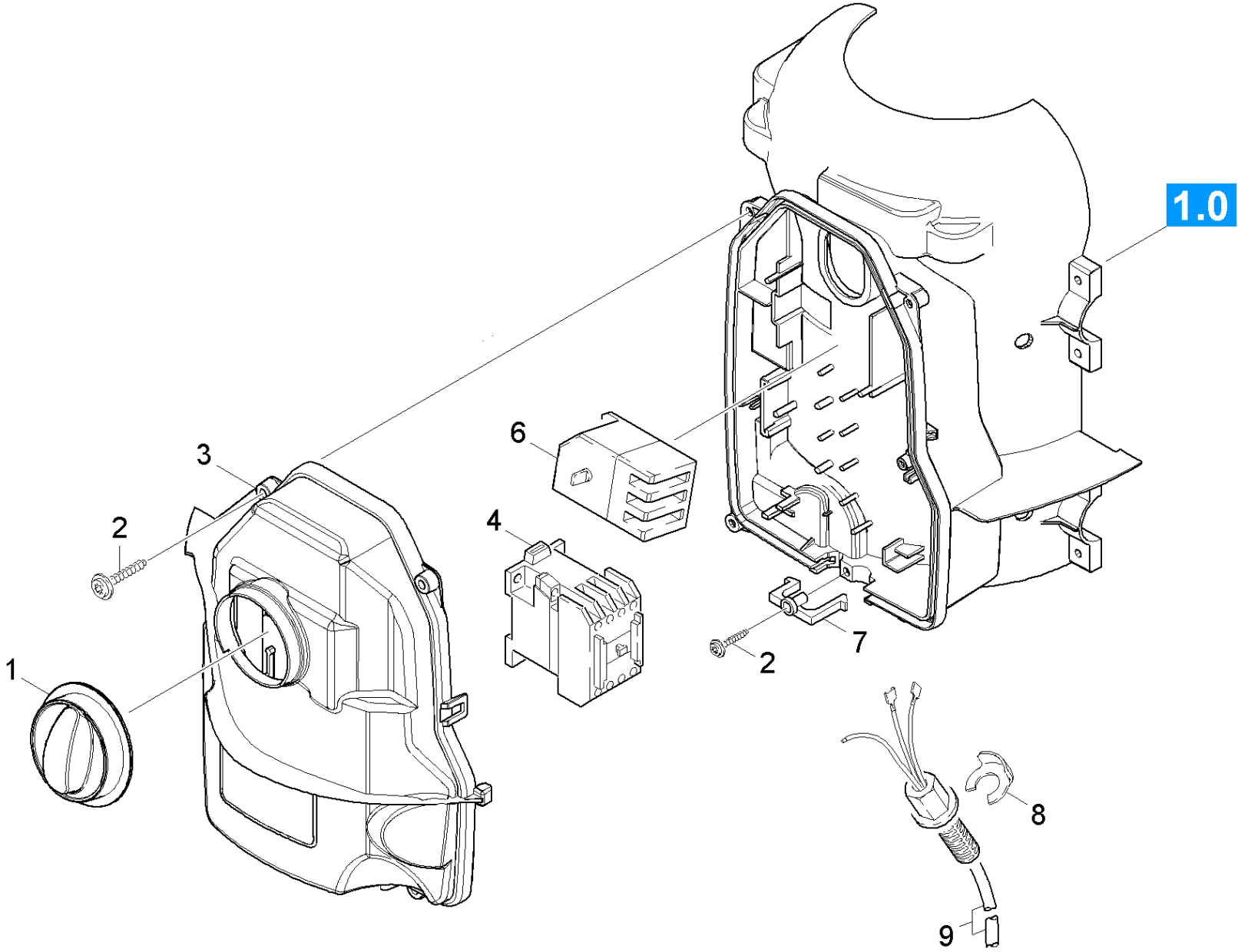

50 Electric box

ET/VT (spare/wear parts)	Pos	Material #	Name	Qty.	Unit	from ser.nr.	up to ser.nr.
X	1	5.322-101.0	Handle yellow	1.000	ST	0000000000	0000000000
	2	6.303-200.0	Screw 5x25-IN6RD	5.000	ST	0000000000	0000000000
	3	5.064-176.0	Cover	1.000	ST	0000000000	0000000000
X-X	4	6.632-414.0	Contacteur LC1-D18V7SC090	1.000	ST	0000000000	0000000000
X	6	6.631-190.0	Motor protecting switch	1.000	ST	0000000000	0000000000
	7	5.263-051.0	Tensioning part	1.000	ST	0000000000	0000000000
	8	6.343-186.0	Locking ring	1.000	ST	0000000000	0000000000
	9	6.649-442.0	Cable with plug	1.000	ST	0000000000	0000000000